

Physics

Question 1

- a) A narrow beam of molecules with a range of different speeds passes through a molecular velocity selector.

The selector comprises two discs rotating in the same direction at the same frequency of rotation f on a common axis in an evacuated container.

The selector allows molecules with particular speeds to pass through.

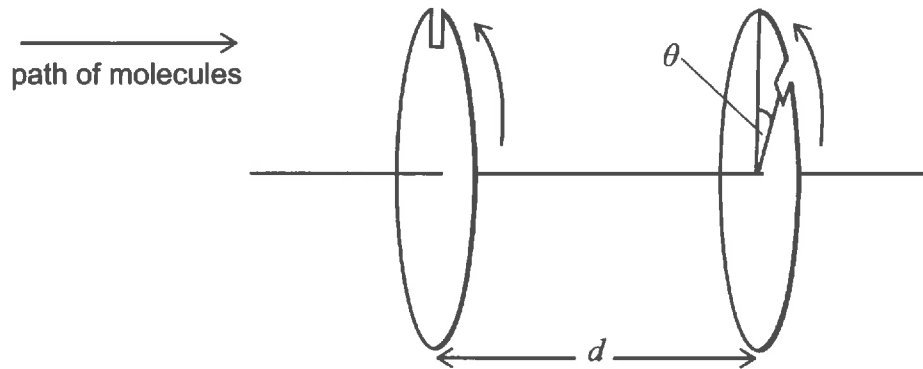

Fig. 1.1

The speeds of the molecules, v , entering the selector vary over a very broad range. The molecules can pass through a very narrow slit on each of the two discs, as shown in Fig. 1.1. The slit on the right-hand disc is displaced by angle θ relative to the slit on the left-hand disc. The horizontal separation of the discs is d .

(The effects of gravity may be ignored and the speed of a molecule within the container remains constant.)

- (i) For $f = 160$ revolutions s^{-1} , how long does it take for the discs to rotate through 1.0° ?

[2 marks]

Answer:

.....

- (i) Rotation in 1 second is $160 \times 360^\circ = 57\,600^\circ$

[1 mark]

.....

For 1.0° , the time taken, $\Delta t = 1.7(4) \times 10^{-5}$ s

[1 mark]

.....

.....

.....

.....

- (ii) If $\theta = 30.0^\circ$, $d = 24.0 \text{ cm}$ and $f = 160 \text{ revolutions s}^{-1}$, what is the highest speed of a molecule that will pass through both slits? **[3 marks]**

Answer:

.....

(ii) Idea that time of flight = time of rotation by θ

$$t = 30^\circ \times \Delta t = 30 \times 1.74 \times 10^{-5} = 5.2 \times 10^{-4} \text{ s}$$

Or $t = \frac{\theta}{\omega} = \frac{\theta}{2\pi f} = \frac{\theta^\circ}{360f} = \frac{30}{360} \times \frac{1}{160} = \frac{1}{1920} \text{ s} = 5.2 \times 10^{-4} \text{ s}$ (all equivalent)

[1 mark]

$$v = \frac{d}{t} = \frac{0.24}{t}$$

[1 mark]

$$v = \frac{0.24}{5.2 \times 10^{-5}} = 460.8 \text{ m s}^{-1} = 461 \text{ m s}^{-1} = 4.6 \times 10^2 \text{ m s}^{-1}$$

[1 mark]

Full marks for the answer.

.....

.....

.....

- (iii) When the speeds of the molecules are measured after they have passed through the two narrow slits, it is found that other molecular speeds are present. Explain why there is more than one speed in the outgoing beam. **[3 marks]**

Answer:

.....

(iii) A set of molecules passing through the first slit will have a (full) range of speeds. [1]

Slower ones will arrive at the second slit when it has rotated by $\theta + 2\pi$ or $\theta + 2n\pi$ (or "made one or more extra rotations") [1]

So there will be a set of discrete speeds in the emerging molecules. [1]

[3 marks]

.....

.....

.....

.....

.....

.....

.....

- (iv) For the arrangement described in (ii), calculate the molecular speed, closest to your value in (ii), that will pass through both slits. [3 marks]

Answer:

.....

..... (iv) Disc must rotate by $360^\circ + \theta$ or $2\pi + \theta$
 $t = \frac{360+30}{360 \times f} = \frac{390}{360 \times 160} = \frac{13}{12 \times 160} = \frac{1}{147.7} \text{ s} = 6.77 \times 10^{-3} \text{ s}$ [1 mark]

..... also same distance d , $v = \frac{d}{t} = \frac{0.24}{t}$, as before [1 mark]

..... Hence $v = 35. (4) \text{ m s}^{-1}$ [1 mark]

.....

Full marks for answer.

.....

.....

.....

.....

.....

- (v) Each slit has an angular width of 0.3° either side of its centre, with the centres of the slits being θ apart. What is the range of speeds ($v_{\max} - v_{\min}$) for the set of molecules referred to in (ii) that pass through both slits? [3 marks]

Answer:

.....

..... (v) $v_{\max} = 0.24 \times 160 \times \frac{360}{29.4} = 470 \text{ m s}^{-1}$ [1 mark]

..... $v_{\min} = 0.24 \times 160 \times \frac{360}{30.6} = 452 \text{ m s}^{-1}$ [1 mark]

..... Range is 18 m s^{-1} but rounding errors may result in 450 to 470 m s^{-1} i.e. 20 m s^{-1} [1 mark]

..... Full marks if 2% variation on 460 (or 461) used for the result.

.....

.....

.....

.....

.....

.....

6.

- b) A particle of mass m falls through height h on to a thin disc rotating at a rate f revolutions s^{-1} . The particle will just fit through a hole in the rotating disc (Fig. 1.2).

(The effects of air resistance may be ignored; take the acceleration due to gravity as 9.81 m s^{-2} .)

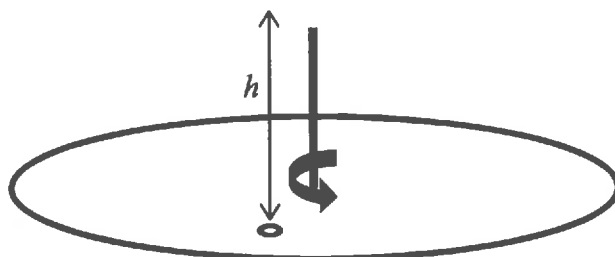

Fig. 1.2

- (i) The disc is rotating at frequency f revolutions s^{-1} when the particle is released from rest. Working in degrees, write down an expression for the angle θ through which the disc will have turned by the time the particle reaches it. **[3 marks]**

Answer:

(i)

$$t = \frac{\theta}{\omega} = \frac{\theta^\circ}{360 \times f} \quad \text{and also } t = \sqrt{\frac{2h}{g}}$$

[1 + 1 mark]

$$\theta^\circ = 360 \times f \times \sqrt{\frac{2h}{g}}$$

[1 mark]

[Or in radians

$$\theta = 2\pi \times f \times \sqrt{\frac{2h}{g}} \quad]$$

- (ii) If $f = 20$ revolutions s^{-1} and a particle, initially at rest, is released at the moment that the hole is vertically below it, what is the minimum height (greater than zero) from which the particle can be dropped so that it will pass through the hole? **[2 marks]**

Answer:

(ii) $t = \sqrt{\frac{2h}{g}}$ and $t = \frac{1}{20}$ s **[1 mark]**

Hence $h = \frac{9.81}{800} = 1.2(3) \times 10^{-2}$ m **[1 mark]**

- (iii) An identical disc with a similar hole is fixed to the same axis, but at a distance $h' = 0.15$ m below it. The two holes are aligned. When the particle is released from rest at a height $h = 0.10$ m above the top disc, it is able to fall through both holes in succession. What is the minimum frequency of rotation (greater than zero) of both discs which will allow this to occur? **[6 marks]**

Answer:

(iii) At the top disc, $v^2 = 2gh$ **[1 mark]**

Time t' is the time taken to fall between the two discs, through height h' .

For falling from top to lower disc, we have initial speed v , time t' , h' .

Then $h' = vt' + \frac{1}{2}gt'^2$ **[1 mark]**

Obtain a quadratic form $h' = \sqrt{2gh} t' + \frac{1}{2}gt'^2$ **[1 mark]** *** alternatives below*

$$t'^2 + \sqrt{\frac{8h}{g}} t' - \frac{2h'}{g} = 0$$

Solving the quadratic $t' = -\sqrt{\frac{2h}{g}} \pm \sqrt{\frac{2}{g}(h+h')}$

$t' = \frac{-1}{\sqrt{9.81}}(\sqrt{2 \times 0.1} \mp \sqrt{2 \times (0.1 + 0.15)})$ only - sign is physical owtte **[1 mark]**

$t' = 0.083$ s **[1 mark]**

this is the time for one full rotation, so $f' = \frac{1}{t'} = 12$ rotations s^{-1} **[1 mark]**

ALTERNATIVES OVERLEAF

** two alternatives for obtaining the quadratic

A. Algebraically $h + h' = \frac{1}{2}g(t + t')^2$ [1 mark]

and also $h = \frac{1}{2}gt^2$ [1 mark]

substituting for h

$$\frac{1}{2}gt^2 + h' = \frac{1}{2}gt^2 + \frac{1}{2}gt'^2 + gtt'$$

To give $h' = \frac{1}{2}gt'^2 + gtt'$ [1 mark]

Then solve as above for remaining three marks.

B. From $v - t$ graph shown below :

$$t = \sqrt{\frac{2h}{g}} \quad [1 \text{ mark}]$$

Area of trapezium $h' = t' \frac{1}{2}(gt + g(t + t'))$ [1 mark]

Substitute for t $h' = gtt' + \frac{1}{2}gt'^2$ [1 mark]

Then solve quadratic as above for remaining three marks.

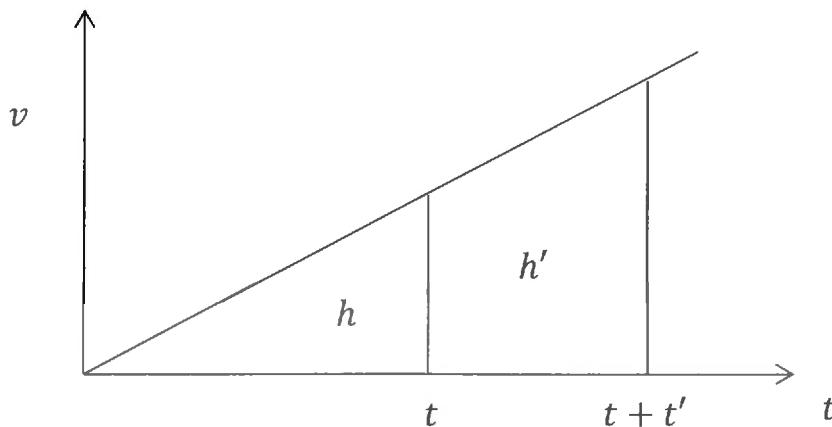

[6 marks]

At the top disc $v = \sqrt{2gh}$ [1 mark]

At the lower disc $v_{final} = \sqrt{2g(h + h')}$ [1 mark]

Average speed between discs, $v_{av} = \frac{1}{2}(\sqrt{2gh} + \sqrt{2g(h + h')})$ [1 mark]

Between discs, $t' = \frac{h'}{v_{av}} = 2h' / (\sqrt{2gh} \left(1 + \sqrt{1 + \frac{h'}{h}}\right))$ [1 mark]

$$t' = 0.083 \text{ s} \quad [1 \text{ mark}]$$

so $f' = \frac{1}{t'} = 12 \text{ rotations s}^{-1}$ [1 mark]

PHYSICS

Question 2

a) Calculate the readings shown on the voltmeter and on ammeters A_1 and A_2 in the circuits shown in Fig. 2.1 (i) and (ii).

(You may assume that the ammeters and voltmeters are ideal and that the cells have negligible internal resistance.)

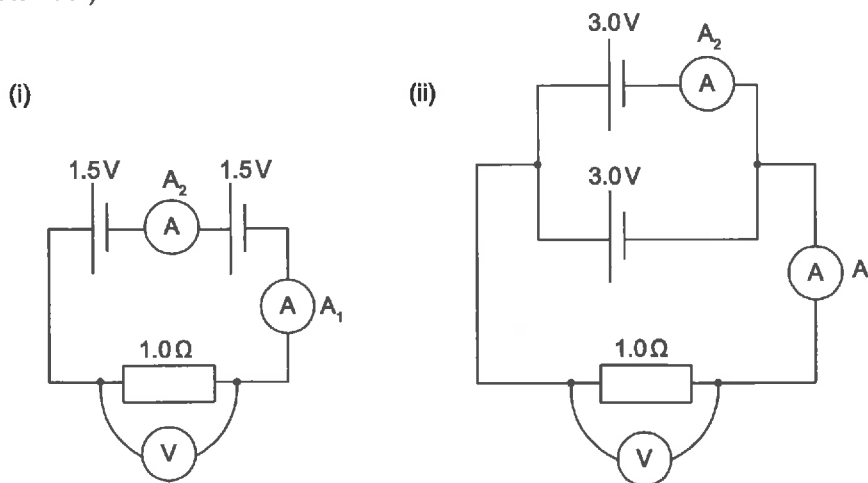

Fig. 2.1

[5 marks]

Answer:

a) marks in section a) are either 1 for correct values or 0 for incorrect values

i) $V = 3.0 \text{ V}$ [1 mark]

$A_1 = A_2 = \frac{V}{R} = 3.0 \text{ A}$ [1 mark]

ii) $V = 3.0 \text{ V}$ [1 mark]

$A_1 = \frac{V}{R} = 3.0 \text{ A}$ [1 mark]

$A_2 = \frac{A_1}{2} = 1.5 \text{ A}$ [1 mark]

.....

.....

.....

.....

.....

.....

.....

.....

.....

.....

- d) A solar cell can be modelled as an ideal cell of 0.50 V in series with an internal resistor of 0.10 Ω. We want to operate a fan that consumes 0.96 W of power and requires a potential difference of 2.4 V. There are 10 identical solar cells available and all must be used. They are arranged as n identical parallel sections with each section consisting of N cells in series. How must they be arranged in the circuit, and what is the current in each solar cell? In both cases explain your reasoning. [4 marks]

Answer:

- d) 5 cells in 2 parallel sections ($n = 2, N = 5$) [1 mark]
 $I = 0.2 \text{ A}$ [1 mark]

Method 1 marks: using “guesswork” & reasoning:

Current required by fan is given by $P = VI \Rightarrow I = 0.4 \text{ A}$ [1 mark]

Potential difference required is 2.4 V which is at least 5 solar cells in series [1 mark]

OR

Method 2 marks: simultaneous equations:

$V = N(\varepsilon - ir)$ { ε = emf, r = internal resistance, V = p.d. required by fan, i = current in each cell, N = the number of cells in each parallel section.} [1 mark]

$I = ni$ (I = current required by fan, n = the number of parallel sections) and $Nn = 10$ [½ + ½ mark]

.....

12.

e) A cell with a potential of 1.5V and zero internal resistance is connected to two resistors in parallel, with values $R_1 = 1.0\ \Omega$ and $R_2 = 2.0\ \Omega$, as shown in Fig. 2.2.

(i) Calculate the current through the cell.

[2 marks]

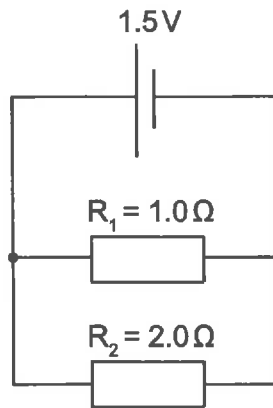

Fig. 2.2

Answer:

.....
.....
.....
.....
.....
.....

e)

i) $R_{\text{eff}} = \left(1 + \frac{1}{2}\right)^{-1} = 2/3\ \Omega$ [1 mark]

$I = \frac{V}{R_{\text{eff}}} = \frac{3}{2} \times \frac{3}{2} = 9/4\ \text{A} (= 2.25\text{A or } 2.3\ \text{A})$ to appropriate sig figs. [1 mark]

.....
.....
.....

- (ii) If the 1.5 V cell in the circuit shown in Fig. 2.2 is replaced with a 1.5 V cell with an internal resistance $r = 0.10 \Omega$, how much power is dissipated in R_2 ? [2 marks]

Answer:

- ii) Realise that the internal resistance adds in series with the effective resistance from e(i)

$$R_{eff} = \frac{1}{10} + \frac{2}{3} = \frac{23}{30} \approx 0.76 \Omega, \text{ therefore the current is now}$$

$$I' = \frac{V}{R_{eff}} = \frac{3/2}{(2/3+1/10)} = \frac{45}{23} \approx 2.0 \text{ (1.96) A.} \quad [1 \text{ mark}]$$

$$\text{Current through } R_2 = I'/3$$

$$\text{therefore power dissipated is } P = (I'/3)^2 R_2 = 0.85 \text{ W} \quad [1 \text{ mark}]$$

Alternative method:

Could use the potential difference across each of the resistors ($\varepsilon - ir$) and solve simultaneous equations. If value is correct full 2 marks if method correct but value wrong, 1 mark.

- (iii) A third resistor $R_3 = 4.0\ \Omega$ is now added in parallel with the first two resistors with the cell from e(ii), as shown in Fig. 2.3. Calculate the current through the cell (which has an internal resistance of $0.10\ \Omega$). [2 marks]

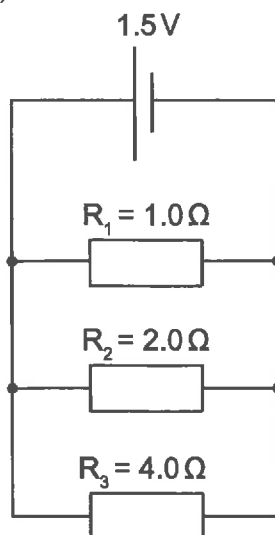

Fig. 2.3

Answer:

iii) $R = \frac{4}{7} + \frac{1}{10} = \frac{47}{70} \approx 0.67\ \Omega$ (0.671 Ω) [1 mark]

$I = \frac{V}{R_{eff}} = \frac{3/2}{47/70} = 105/47 \approx 2.2\ \text{A}$ (2.23 A) [1 mark]

NB:

If students have neglected the internal resistance they should be given **0 marks**.

The values without internal resistance are $4/7\ \Omega$, 2.6 A

- (iv) More and more resistors are now added, one by one, in parallel with the existing ones, each with double the resistance of the previous one. The final circuit consists of resistors with values of $1\ \Omega$, $2\ \Omega$, $4\ \Omega$, $8\ \Omega$, $16\ \Omega$, $32\ \Omega$, $64\ \Omega$, ... connected in parallel with the cell. Calculate the total current through the cell if the number of resistors is infinite.

[3 marks]

Answer:

- iv) Realising that the reciprocal of the effective resistance of the circuit is an infinite sum of a geometric series such that

$$\frac{1}{R_{eff}} = 1 + \frac{1}{2} + \frac{1}{4} + \dots = \frac{a}{1-r} = \frac{1}{1-\frac{1}{2}} = 2 \quad [1 \text{ mark}]$$

$$R_{eff} = \frac{1}{\frac{1}{2} + \frac{1}{10}} = \frac{6}{10} = 0.6\ \Omega \quad [1 \text{ mark}]$$

$$I = \frac{V}{R_{eff}} = \frac{3/2}{6/10} = 15/6 = 2.5\ \text{A} \quad [1 \text{ mark}]$$

NB:

If students have neglected the internal resistance they should be given the benefit of the doubt in this case as the question is more ambiguous.

The values without the internal resistance are

$$R_{eff} = \frac{1}{2} \quad [2 \text{ marks}]$$

$$I = \frac{V}{R_{eff}} = 3.0\ \text{A} \quad [1 \text{ mark}]$$

Question 3

Parts a), b) and c) can be answered independently of one another.

- a) Draw two alternative 'dot and cross' diagrams to describe the bonding in the linear thiocyanate anion SCN^- . In one diagram place the negative charge on the sulfur, and in the other place the negative charge on the nitrogen.

[5 marks]

Answer:

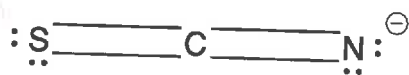
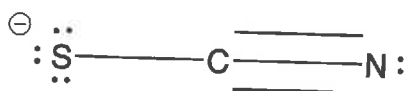

Any variant on these (using lines to represent bonds and/or dot/cross pairs) is acceptable. Crucial thing is to have electron count correct and correct location of lone pairs.

(designed to be 'easy marks')

- b) Breakfast cereals frequently have elemental iron added to them as a dietary supplement. A method for making a quantitative measurement of the amount of iron is to use the reaction between $\text{Fe}^{3+}(\text{aq})$ and thiocyanate, $\text{SCN}^{-}(\text{aq})$, which gives the deep red complex $\text{FeSCN}^{2+}(\text{aq})$.



The depth of the colour can be measured using a *spectrophotometer* which gives a value for the *absorbance* that is proportional to the concentration of the complex:

$$\text{absorbance} = \text{constant} \times [\text{FeSCN}^{2+}] \quad \text{Equation 1}$$

The constant can be found by measuring the absorbance of a solution of known concentration.

- (i) The absorbance of a solution of the complex with concentration $2.5 \times 10^{-4} \text{ mol dm}^{-3}$ was measured to be 1.85; determine the value of the constant in Equation 1. **[2 marks]**

Answer:

$$\text{constant} = \frac{1.85}{2.5 \times 10^{-4}} = 7400 \text{ mol}^{-1} \text{ dm}^3$$

Units not expected; any reasonable sig. fig. acceptable.

100g of breakfast cereal was mixed with sufficient dilute acid to dissolve all of the iron. The solution was carefully filtered and mixed with sufficient oxidising agent to convert all of the iron to Fe^{3+} . The solution was made up to a total volume of 250 cm^3 . 10.0 cm^3 of this solution was mixed with 10.0 cm^3 of a solution of thiocyanate; you may assume that all of the iron is converted to the complex. The absorbance of the resulting solution was measured as 0.519.

- (ii) Using the value of the constant found in (i), calculate the concentration of Fe^{3+} in the solution for which the absorbance was measured. **[2 marks]**

Answer:

There are many possible approaches to this: full credit for any valid approach. Full marks for valid approach and correct answer. Any reasonable sig. fig. for answer acceptable.

$$[\text{Fe}^{3+}] \text{ in the measured solution} = \frac{0.519}{7400} = 7.0135 \times 10^{-5} \text{ mol dm}^{-3}$$

(iii) Hence calculate the concentration of Fe^{3+} in the solution prepared from the cereal.

[2 marks]

Answer:

[Fe^{3+}] in the 10 cm^3 portion of the extract is twice this = $1.403 \times 10^{-4} \text{ mol dm}^{-3}$; this is the concentration in the 250 cm^3 of extract that was made.

(iv) Hence calculate the mass of iron present in the 100 g of breakfast cereal (A_r : Fe = 55.85).

[4 marks]

Answer:

no. of moles in 250 cm^3 solution with this conc = $1.403 \times 10^{-4} \times \frac{250}{1000} = 3.507 \times 10^{-5}$

convert this to mass of Fe

mass of Fe in 250 cm^3 solution with this conc = $3.507 \times 10^{-5} \times 55.85 = 1.96 \times 10^{-3} \text{ g}$

This is the mass in 100 g of cereal.

c) Hydrogen peroxide, H_2O_2 , is used as the oxidising agent to convert Fe^{2+} to Fe^{3+} in the assay described in b)(ii).

(i) Determine the oxidation state of oxygen in H_2O_2 .

[2 marks]

Answer:

..... Let x be the oxidation state of O, assume oxidation state of H is +1; species is neutral so

.....
$$2 \times (+1) + 2 \times x = 0$$

..... Hence $x = -1$

.....

.....

.....

.....

(ii) When H_2O_2 acts as an oxidising agent in acidic solution, what is the oxygen-containing species that is produced and what is the oxidation state of oxygen in this species?

[4 marks]

Answer:

.....

..... (ii) H_2O_2 is reduced to H_2O . Oxidation state of O in H_2O is -2

.....

.....

.....

.....

.....

.....

.....

.....

.....

.....

.....

.....

.....

.....

.....

.....

.....

.....

.....

.....

.....

.....

.....

.....

.....

2 marks
for each

- (iii) Write a balanced chemical equation describing the oxidation of $\text{Fe}^{2+}(\text{aq})$ to $\text{Fe}^{3+}(\text{aq})$ by H_2O_2 in acidic solution. [4 marks]

Answer:



Looking for charges and atoms to balance; not worried about (aq) etc; H_3O^+ fine instead of H^+ .

CHEMISTRY

Guidance for markers — not the expected answer from candidates

~~analysis~~

The overall scheme is

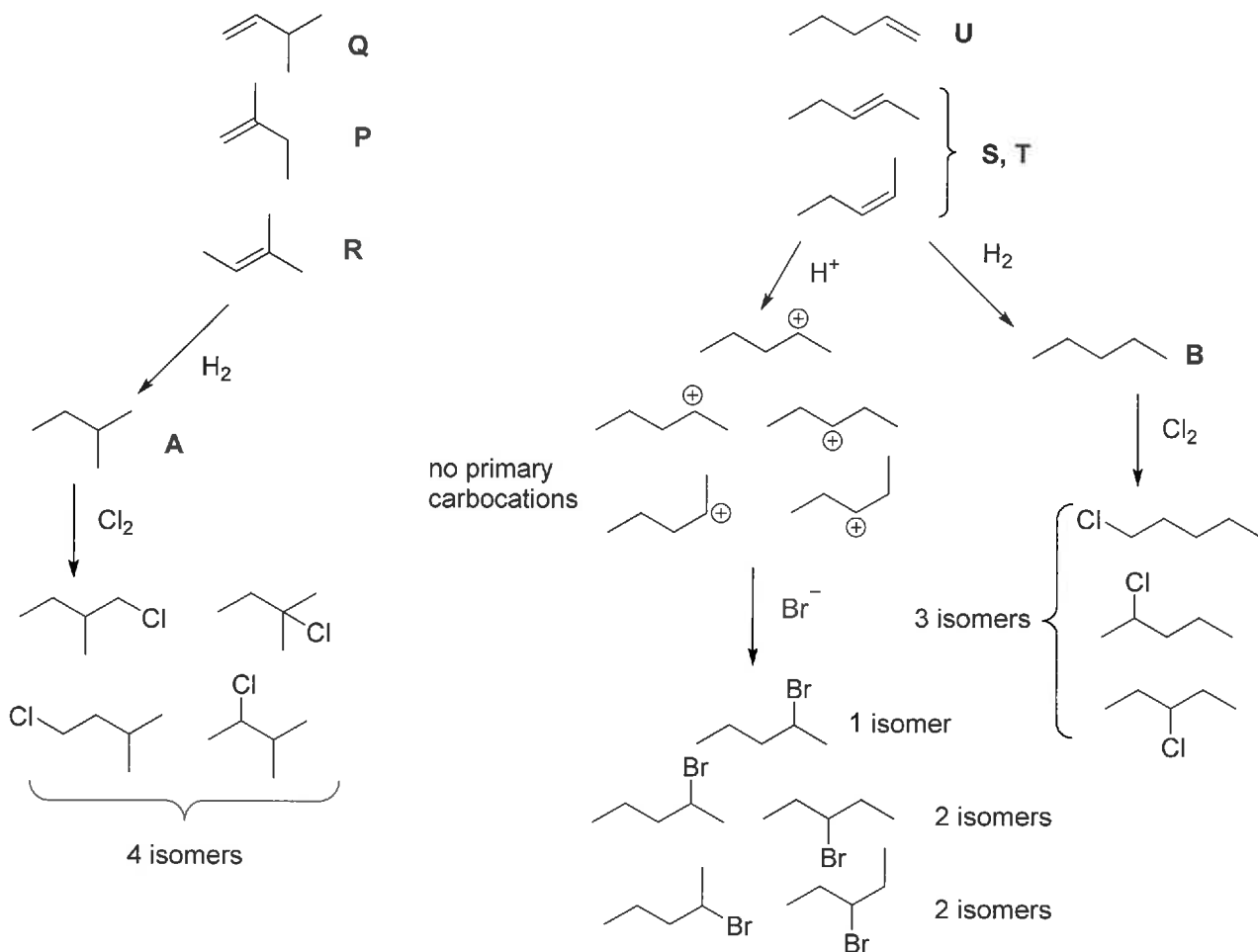

This page is intentionally left blank for your rough working or notes.

Question 4

There are six isomers with the formula C_5H_{10} that are alkenes. The alkenes all have different enthalpies of formation, all of which are negative.

a) Draw the structures of the six alkenes (skeletal or displayed structures are acceptable).

[6 marks]

Answer:

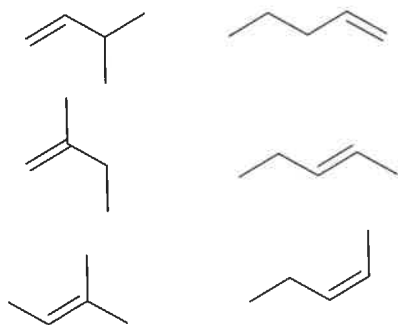

Other ways of writing out the structures are fine as long as they are clear

Samples of the six alkenes, in a random order, are labelled **P**, **Q**, **R**, **S**, **T**, and **U**. You will be able to identify which isomer *some* of these correspond to using the information and data throughout the rest of the question.

Alkenes **P**, **Q**, and **R** react with hydrogen gas and a metal catalyst to give the same alkane **A**; alkenes **S**, **T**, and **U** react under the same conditions to give a different alkane **B**.

Both alkanes **A** and **B** react with chlorine gas under UV light to form chloroalkanes with the formula $C_5H_{11}Cl$. Under such conditions, alkane **A** forms *four* different structural isomers, whereas **B** gives *three*.

- b) Draw the structures of alkanes **A** and **B**. Also draw the structures of the four isomers arising from the chlorination of **A**, and the three isomers arising from the chlorination of **B**. [6 marks]

Answer:

Realise that there are only two hydrogenation products

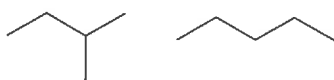

Chlorination of these gives several products corresponding to putting one Cl onto each distinct carbon

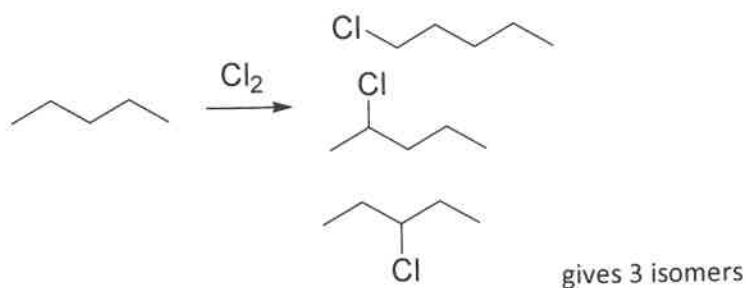
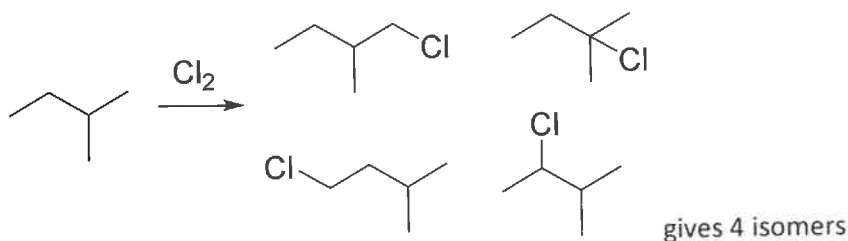

Identifies

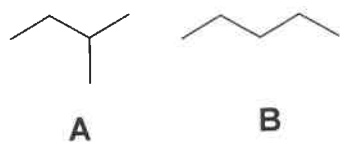

N.B. reasoning is not requested
or required

The alkenes react with HBr to form bromoalkanes with the formula $C_5H_{11}Br$; the reaction proceeds via a carbocation intermediate. Alkenes **S** and **T** give a mix of *two* structural isomers, whereas alkene **U** gives only one.

c) Give the structure of alkene **U**.

[4 marks]

Answer:

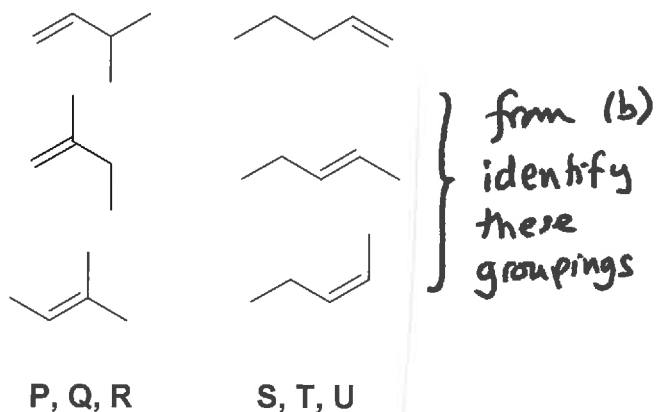

The cations arising from **S, T, U** group are (primary excluded)

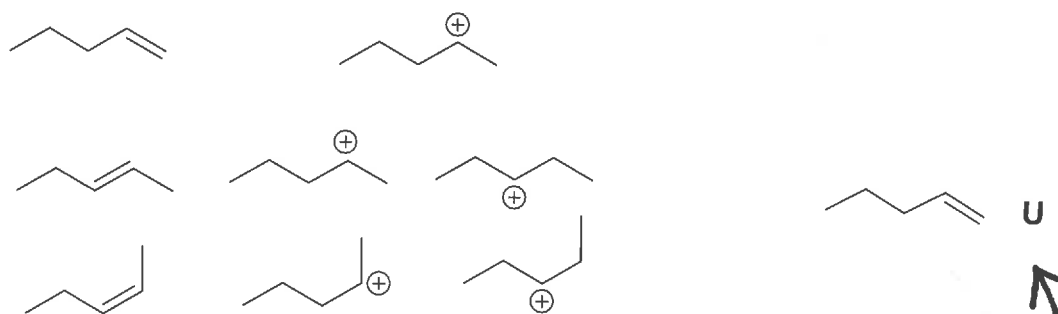

Only the first one will give one isomer on subsequent reaction with Br^- , identifying

A general rule for isomeric alkenes is that the more carbon atoms directly bonded to the double bond (or the lower the number of hydrogen atoms directly bonded), the more negative (that is, the more exothermic) the enthalpy of formation of the alkene.

d) Out of **P, Q** and **R**, **R** has the most negative (most exothermic) enthalpy of formation. Give the structure of **R**.

[1 mark]

Answer:

Out of **P, Q** and **R**, the one with the most carbons attached to the double bond is

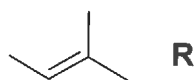

R has the most negative (most exothermic) enthalpy of formation.

Consider the following thermodynamic data:

	value / kJ mol^{-1}
standard enthalpy change of hydrogenation for alkene P	-113
standard enthalpy change of hydrogenation for alkene Q	-119
standard enthalpy change of combustion for alkane A	-3528
standard enthalpy change of formation of $\text{H}_2\text{O}(\text{l})$	-286

e) Use the data to deduce the structure of: (i) alkene **P**; and (ii) alkene **Q**.

[4 marks]

Answer:

Hydrogenation of both **P** and **Q** gives **A**, we can assess the enthalpies of formation of **P** and **Q** by comparing their enthalpies of hydrogenation.

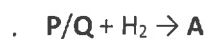

ΔH for this reaction is $\Delta_r H(\text{hydrogenation}) = \Delta_f H(\text{A}) - \Delta_f H(\text{P/Q})$

hence $\Delta_f H(\text{P/Q}) = \Delta_f H(\text{A}) - \Delta_r H(\text{hydrogenation})$.

Since $\Delta_r H(\text{hydrogenation})$ is more negative for **Q** than for **P**, $-\Delta_r H(\text{hydrogenation})$ is more positive for **Q** than for **P**. It follows that $\Delta_f H(\text{Q})$ is larger than $\Delta_f H(\text{P})$ i.e. $\Delta_f H(\text{Q})$ is less negative than $\Delta_f H(\text{P})$. **P** therefore has the more substituted double bond

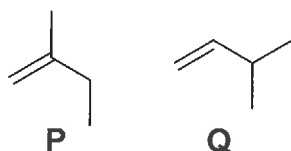

An alternative is to work out $\Delta_r H$ for $\text{P} \rightarrow \text{Q}$ in the following way

$$\Delta_r H(\text{hydrogenation P}) = \Delta_f H(\text{A}) - \Delta_f H(\text{P}) \quad -113 \text{ kJ mol}^{-1}$$

$$\Delta_r H(\text{hydrogenation Q}) = \Delta_f H(\text{A}) - \Delta_f H(\text{Q}) \quad -119 \text{ kJ mol}^{-1}$$

subtracting second from first gives

$$\Delta_r H(\text{hydrogenation P}) - \Delta_r H(\text{hydrogenation Q}) = \Delta_f H(\text{Q}) - \Delta_f H(\text{P}) \quad -113 + 119 = 6 \text{ kJ mol}^{-1}$$

This is $\Delta_r H$ for $\text{P} \rightarrow \text{Q}$. The positive value implies that $\Delta_f H(\text{P})$ is more negative than $\Delta_f H(\text{Q})$: **P** has the more substituted double bond.

f) Use the data to calculate the standard enthalpy change of combustion of alkene P.

[4 marks]

Answer:

.....

.....

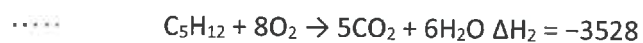
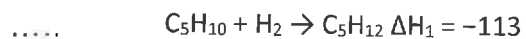

..... Adding all three gives

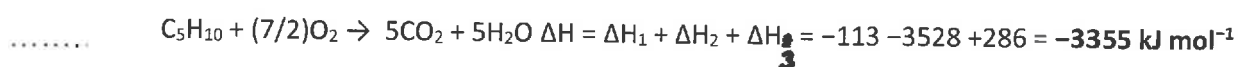

.....

.....

.....

.....

.....

.....

.....

Biology

Question 5

EcoRI is a restriction enzyme that cuts bacterial DNA into pieces at specific sequences.

a) What type of biological molecule is *EcoRI*?

[1 mark]

Answer: **1 mark: a Protein**

b) Name the type of bond between adjacent nucleotides that is cut by *EcoRI*.

[1 mark]

Answer: **1 mark: Phosphodiester bond 1/2 mark: Covalent bond**

c) *EcoRI* cuts at specific sites in the DNA, characterised by the sequence GAATTC. Other restriction enzymes cut at specific sequences like GGATCC or AGCT. What characteristic do these sequences have in common and how might this characteristic aid in cutting?

[3 marks]

Answer:

2 marks: Identifying that these sequences are palindromic, and so reading 5' to 3' forward on one strand matches the sequence reading backward 5' to 3' on the complementary strand.

1 mark: Identifying that this type of sequence allows the same enzyme to make cuts on both strands at the same site.

d) *EcoRI* is produced by bacteria. What role might it have in a bacterial cell?

[1 mark]

Answer: **1 mark: To cut viral DNA (as a defence mechanism).**

- e) We can use different restriction enzymes to cut DNA at different sites. Another restriction enzyme is *Bam*HI. By studying the fragments produced by different combinations of restriction enzymes we can produce a map of the cutting sites of these enzymes.

Use the data in the table below to produce a map of the cutting sites of restriction enzymes. This map should be drawn onto a circle of bacterial plasmid DNA, the total length of which is 18 kb. Distances between the cut sites should be identified. **[4 marks]**

<i>enzyme used</i>	<i>fragment sizes produced / kb</i>
<i>Eco</i> RI alone	6, 12
<i>Bam</i> HI alone	7.5, 10.5
<i>Eco</i> RI and <i>Bam</i> HI together	3, 3, 4.5, 7.5

Answer:

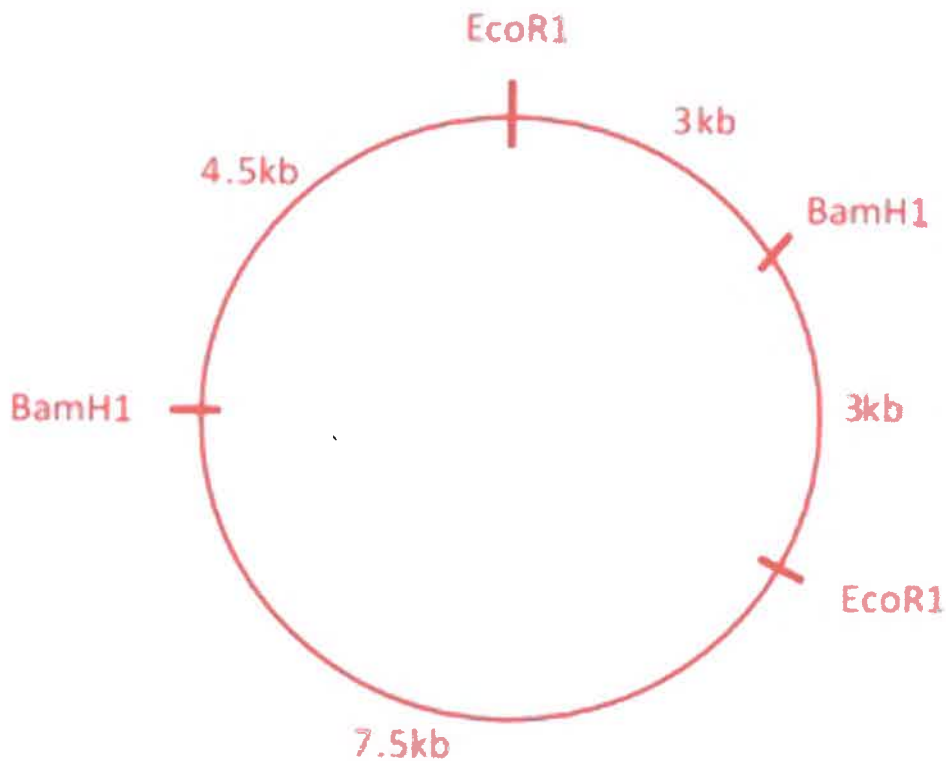

- 1 mark for drawing a circle with cuts
- 1 mark for identifying correct number of cuts
- 1 mark for correct labelling
- 1 mark for correct diagram (although the one above could be mirrored)

f) Suggest how enzymes like *EcoRI* could be used in genetic engineering.

[3 marks]

Answer:

1 mark: Identifying that genes from humans and other organisms can be 'cut out' using enzymes and transferred to cells of other organisms.

1 mark: Identifying that if transferred into a bacterium, the bacterium will produce the protein product.

1 mark: Specific example.

1 mark: Discussion of the modification of a genome to cure disease.

Maximum 3 marks awarded.

This page is intentionally left blank for your rough working or notes.

- g) *EcoRI* is produced by bacteria that often live harmlessly inside the human body. Explain how temperature and pH might affect the activity of *EcoRI* in bacterial cells, using diagrams if necessary. [12 marks]

Answer:

2 marks: Identifying that as temperature increases, the kinetic energy increases and enzymes will work at higher rate (provided that all the other limiting factors are in optimal supply) until the optimum temperature is reached (likely 37°C for enzymes adapted to the human body).

2 marks: Identifying if the temperature increases further, bonds that keep the enzyme (and substrate) structure in place will be altered and so binding will be altered and the rate of reaction will decrease. At high temperatures, denaturation may occur.

2 marks: Drawing a diagram of the changing rates of reaction (or explaining this in detail). Axes should be labelled.

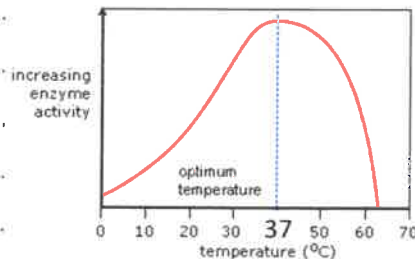

2 marks: Identifying that pH affects enzymes' activity because changes in H⁺ and OH⁻ affect the bonds within them. Such changes can affect the tertiary structure of the enzyme, denaturing it at extremes.

2 marks: identifying that alteration of the structure of the enzyme (and substrate) will affect binding of the substrate and thus the rate of reaction. The enzyme will have a pH optimum (ECOR1 = 7.5). Below or above the optimum, the enzyme will work at a lower rate.

2 marks: Drawing of a diagram of the changing rates of reaction (or explaining this in detail). Axes should be labelled.

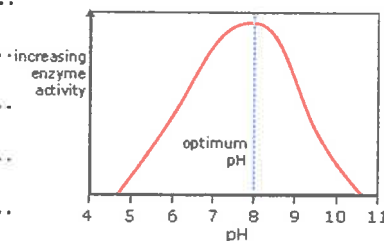

Up to 2 marks may be deducted for particularly incoherent arguments.

Note that for this section, sample scripts will be circulated by Friday 11th November for comparison.

Question 6

Below are images of three species of organism, all of which are vermiform (worm-like) in appearance.

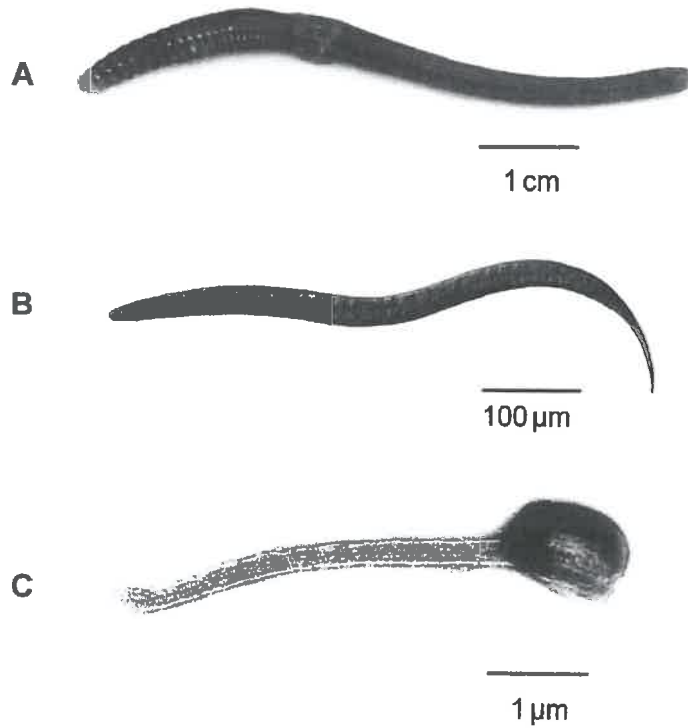

a) What is the approximate length of each species in mm? [3 marks]

Answer:

A. **1 mark: 60mm +/- 15mm**

B. **1 mark: 0.6mm +/- 0.15mm**

C. **1 mark: 0.005mm +/- 0.0015mm**

b) What type of microscope has been used to produce the images of organisms B and C? [2 marks]

Answer:

B. **1 mark: Light microscope**

C. **1 mark: Electron microscope (TEM)**

- c) For organism A, treating it as a tube, estimate the surface area:volume ratio, working in mm. Show your working.

[4 marks]

Answer:

By treating the worm as a cylinder, the ratio comes out as approximately:

1.5 mm⁻¹ OR approximately 2/R

Values between 1 mm⁻¹ and 2mm⁻¹ will be accepted, provided that working is correct (i.e do not punish if estimates are poor).

1 mark: correct equations (for tube or alternative)

1 mark: correct equation manipulation

1 mark: correct answer

1 mark: correct units

A summary of how they might do this is detailed below.

The student needs to use an approximation and treat the organism as an easily quantifiable object, ie a cylinder. However, the answer can vary depending on the level of approach used.

Finest level: the student will try to answer in a general mathematical way as below:

The worm is a cylinder, L = height of the cylinder and R = is the radius

The volume (V) will be $\rightarrow V = L \pi R^2$

The surface area (S) will be $\rightarrow S = L 2\pi R + 2\pi R^2$

Because in this organism/cylinder $L \gg R$ we can ignore $2\pi R^2$ and say that $S = L2\pi R$

Then the ratio S over V is $\rightarrow S/V = L2\pi R / L \pi R^2 = 2/R$

So the solution is 2/R

Other approach: The student may approach the problem in the correct way – i.e. use the approximation of the worm being a cylinder – and calculate the S over V ratio using the formulae of V and S and coming up with a number. Of course, the numerical value will change depending on the estimate they give for L and R (according to the reference bar provided). When giving the numerical value it is important the student recognises that the ratio S over V has the dimension of cm⁻¹ (or mm⁻¹, depending on the unit they use). So 1.5 of the answer is correct only if they express the values in mm.

d) How will the surface area:volume ratio differ between the three organisms?

[2 marks]

Answer:

2 marks: It will decrease as size gets bigger

.....
.....
.....
.....
.....
.....

e) Identify four substances that organism A may need to exchange with the external environment.

[2 marks]

Answer:

½ mark for each of:

Oxygen

CO₂

Urea

Glucose

Viable alternatives

.....
.....

This page is intentionally left blank for your rough working or notes.

- f) Discuss how the size of organisms affects their ease of exchange of substances with the external environment. You should highlight at least two adaptations that help overcome the constraints of size.

[12 marks]

Answer:

2 marks: Identifying that adaptations to increase surface areas for exchange are often necessary in large animals.

2 marks: Identifying that in some small animals, exchange of substances over their surface may be an issue (e.g with dehydration)

4 marks: Detailed explanation of one adaptation that may help facilitate or prevent exchange. Adaptations may include root hairs, gills, lungs, etc. One mark should be deducted if students do not highlight at least two characteristics of each adaptation (e.g. S.A, short diffusion distance, counter-current exchange etc). One mark should be deducted if no numerical values are given.

4 marks: Detailed explanation of a second adaptation that may help facilitate or prevent exchange. Adaptations may include root hairs, gills, lungs, etc. One mark should be deducted if students do not highlight at least two characteristics of each adaptation (e.g. S.A, short diffusion distance, counter-current exchange etc). One mark should be deducted if no numerical values are given.

Up to 2 marks may be deducted for particularly incoherent arguments.

Note that for this section, sample scripts will be circulated by Friday 11th November for comparison.

